

Phaser™ PX  
 Phaser™ PXi  
 Phaser™ II PX  
 Phaser™ II PXi  
 Phaser™ II PXe  
 Phaser™ II SX/DX  
 Phaser™ IISD/SDX  
 Phaser™ III PXi  
 Phaser™ 300i  
 Phaser™ 200i and 220i  
 Phaser™ 200e and 220e

## 4-Mbyte RAM SIMM Installation — (4690F4M)

### Finding your printer's SIMM installation instructions

If your printer is a ...	Then go to page ...
Phaser PX	2
Phaser PXi	2
Phaser II PX	6
Phaser II PXi (slide-in style image processor board)	6
Phaser II PXe	9
Phaser II PXi (bolt-down style image processor board)	9
Phaser III PXi and Phaser 300i	12
Phaser II SX/DX (slide-in style image processor board)	14
Phaser II SX/DX (bolt-down style image processor board)	17
Phaser IISD/SDX	20
Phaser 200i and 220i	23
Phaser 200e and 220e	23

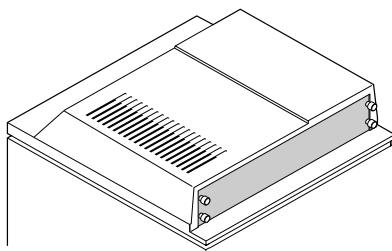

**Slide-in style image processor board  
(note the four thumbscrews)**

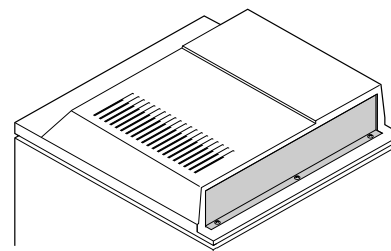

**Bolt-down style  
image processor board**

## Static electricity precautions

- Leave the printer plugged into its power outlet. This preserves a ground path for static discharges.
- Touch the printer's bare metal frame often to discharge static electricity from your body.
- Handle the circuit board(s) by their edges only.
- Do not lay the board(s) on a metal surface.
- Make the least possible movements to avoid generating static electricity.
- Avoid wearing nylon or polyester clothing; they generate static electricity.

## Phaser PX Phaser PXi

1. Power down the printer. Do not unplug the printer; this preserves a ground path to dissipate static charges. Disconnect the host interface cables.
2. Remove the printer's upper half cover by first lifting the rear corners of the cover and then the front corners.

3. Remove the EMI shield.

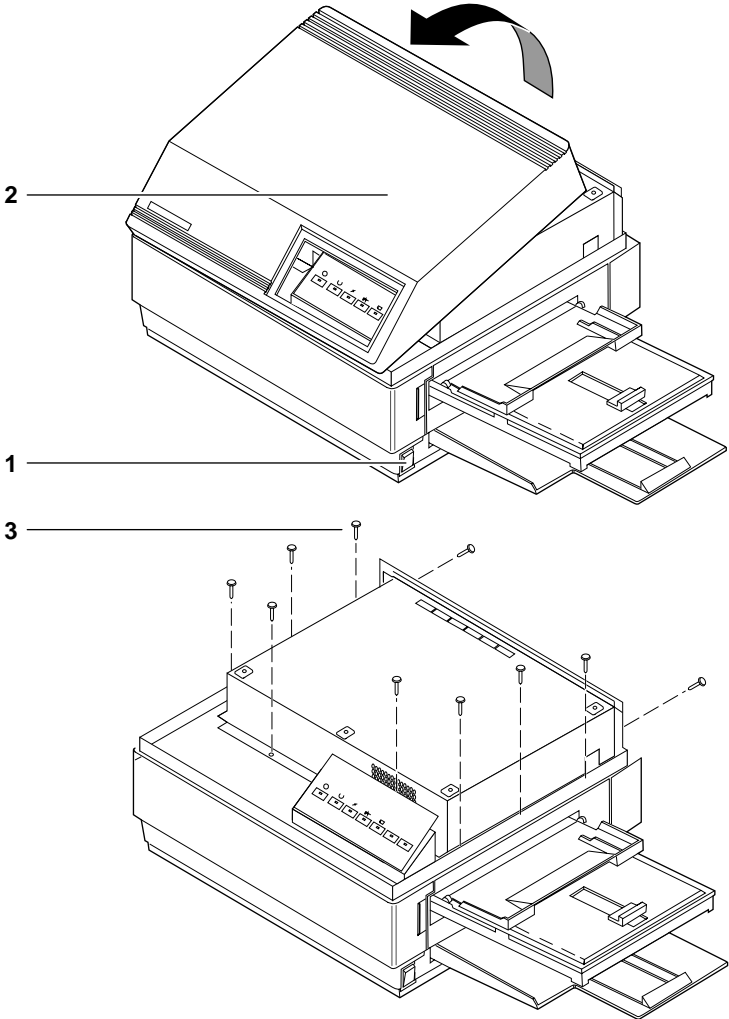

4. **PX image processor:** Locate the RAM SIMM connector on the image processor board. It is labeled J229 (on older-version boards it is labeled J335).
  - a. Insert the RAM SIMM in J229 (or J335).
  - b. Angle the RAM SIMM into its connector; it should lock in place when properly installed.

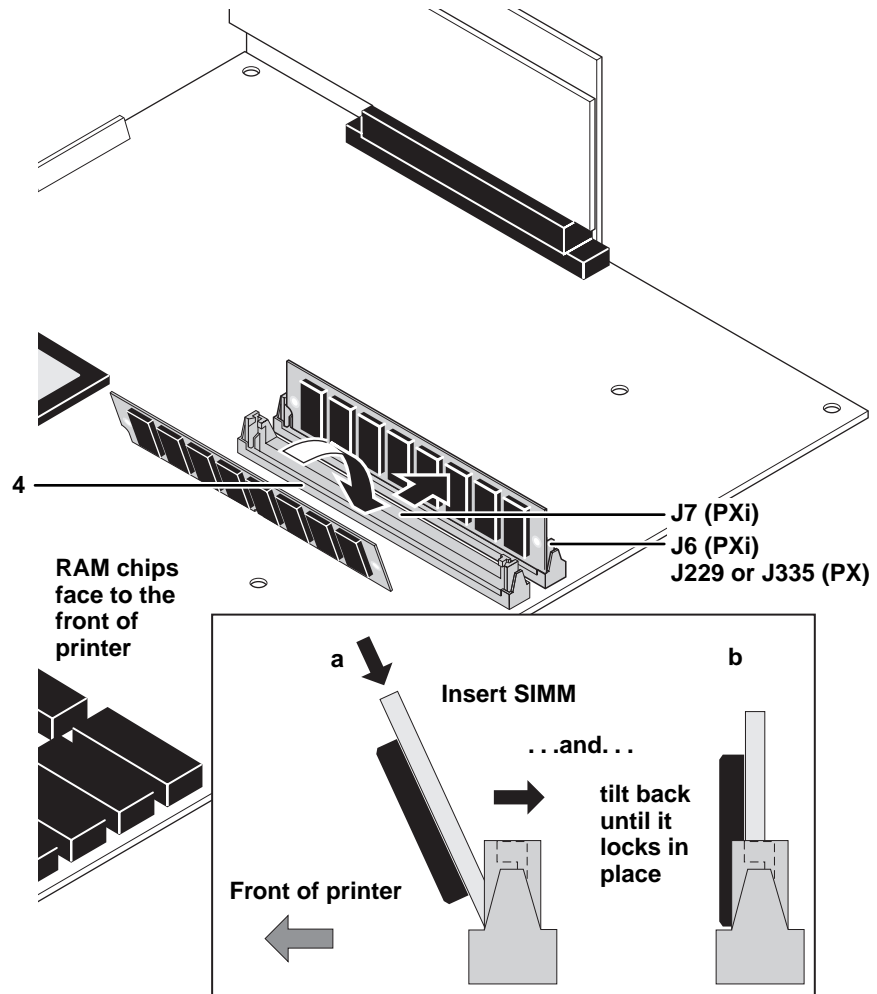

**Note** For the PXi image processor: Install memory modules in the order J6 and then J7.

**PXi image processor:** Insert a DRAM SIMM in connector J6 (or in J7 if J6 is already filled) **(a)**, and tilt the module upright until it locks in place **(b)**. Repeat Step 4 to install additional memory modules.

When properly inserted, a tab on each end of the connector slips into a hole on each end of the RAM SIMM. Also, a pawl on each end of the connector latches around each end of the RAM SIMM to lock it in place.

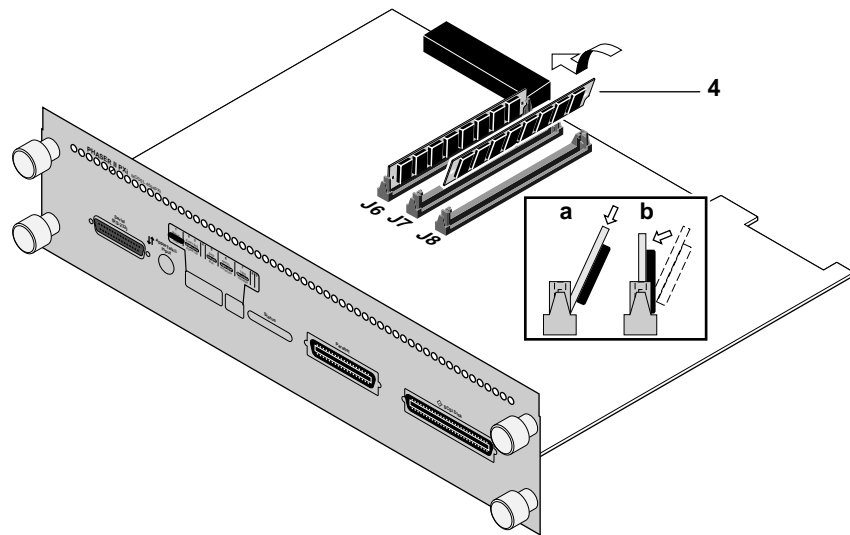

5. Reinstall the EMI shield and the top panel.
6. Reconnect the host interface cables. Turn on the printer and make a print to ensure that the printer functions correctly.

**Phaser II PX  
Phaser II PXi  
(slide-in style image processor board)**

1. Power down the printer. Do not unplug the printer; this preserves a ground path to dissipate static charges. Disconnect the host interface cables.
2. Unscrew the four thumbscrews securing the image processor board's rear panel to the printer. Slide the image processor board out of the printer.

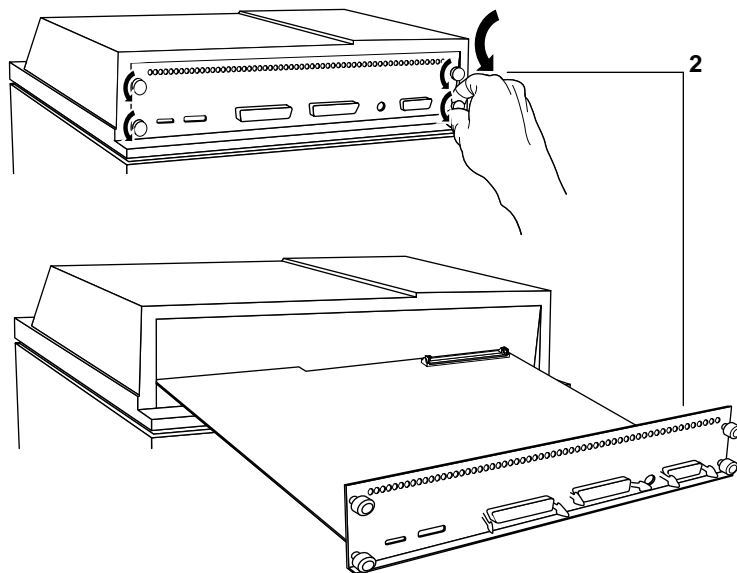

3. Locate the SIMM connectors:
  - Labeled J160 on the PX image processor board
  - Labeled J6 on the PXi image processor board
4. **PX image processor:** Insert a memory module in connector J160 (a), and tilt the module upright until it locks in place (b).

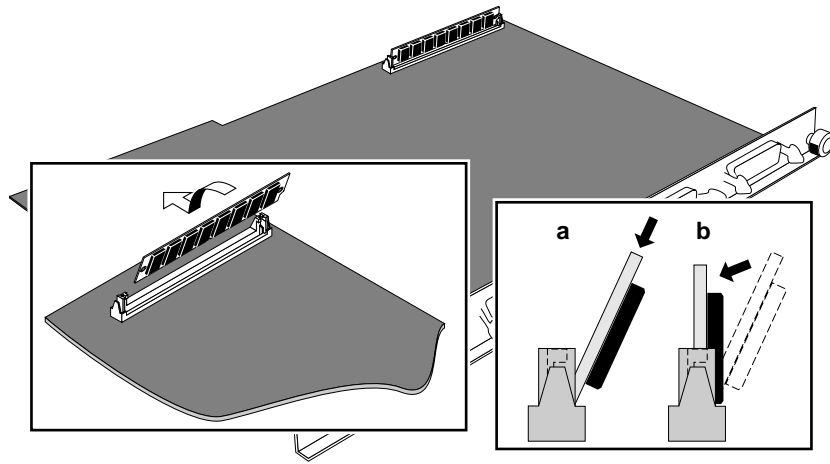

**Note** For the PXi image processor: Install memory modules in the order J6 and then J7.

**PXi image processor:** Insert a memory module in connector J6 (or in J7 if J6 is already filled) (a), and tilt the module upright until it locks in place (b). Repeat Step 4 to install additional memory modules.

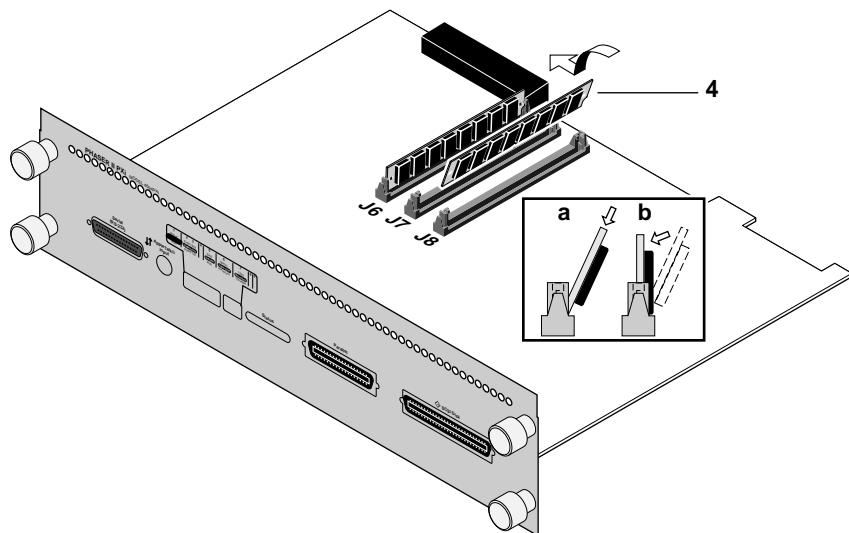

When properly inserted, a tab on each end of the connector slips into a hole on each end of the RAM SIMM. Also, a pawl on each end of the connector latches around each end of the RAM SIMM to lock it in place.

5. Reinstall the image processor board in place and secure with the thumbscrews.
6. Reconnect the host interface cables. Turn on the printer and make a print to ensure that the printer functions correctly.



## Phaser II PXe and Phaser II PXi (bolt-down style image processor board)

1. Power down the printer. Do not unplug the printer; this preserves a ground path to dissipate static charges. Disconnect the host interface cables.
2. Remove the top panel. (Lift it carefully; the front panel LED cable is still connected.)
3. Disconnect the front panel LED connector.

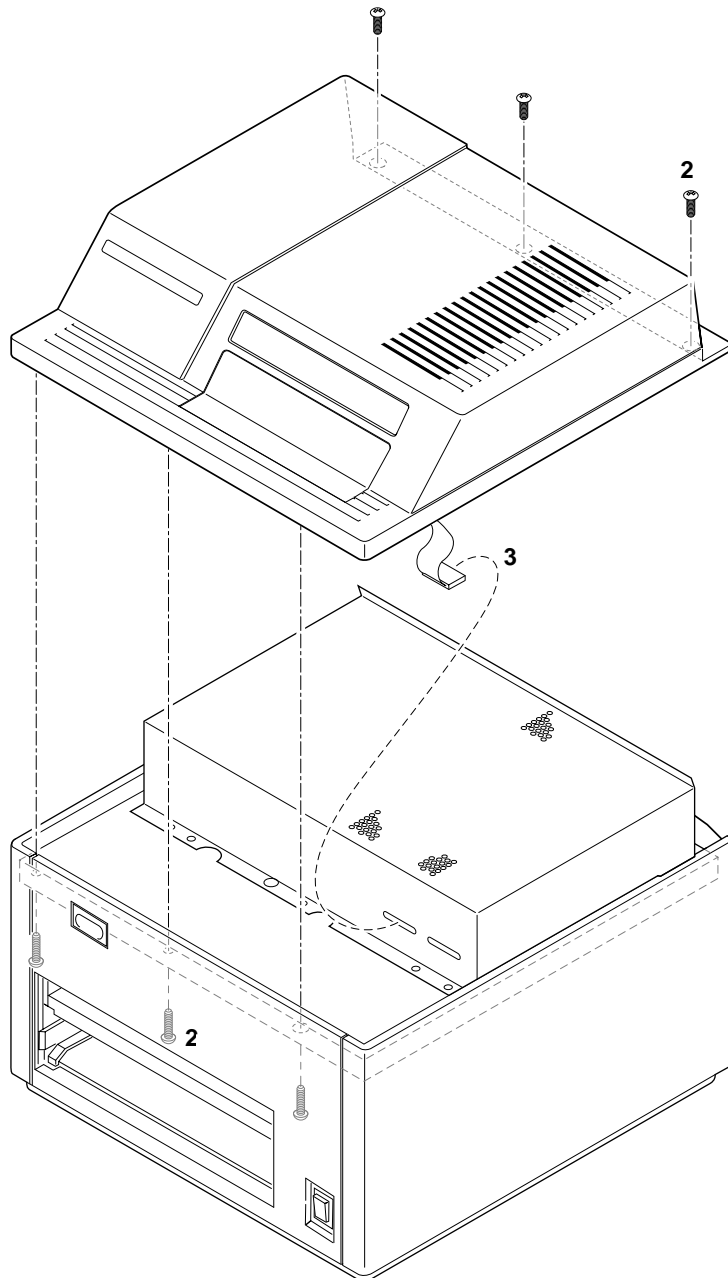

4. Remove the two screws securing the front of the EMI shield. Tilt the shield up and remove it.

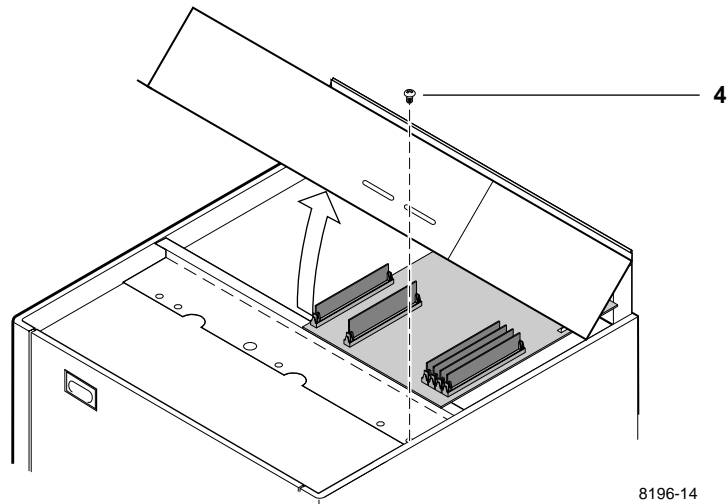

5. Locate the DRAM SIMM module connector J6.
6. **PXe image processor:** Insert the DRAM SIMM in connector J6 (a) and tilt the module upright until it locks in place (b).

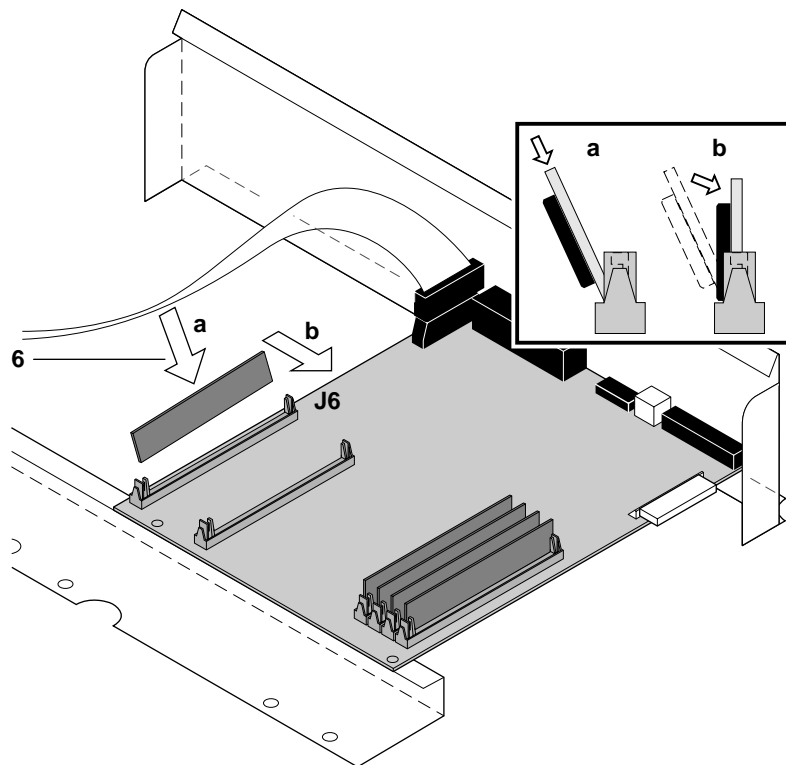

When properly inserted, a tab on each end of the connector slips into a hole on each end of the memory module. Also, a pawl on each end of the connector latches around each end of the memory module to lock it in place.

**Note** For the PXi image processor: Install DRAM modules in the order J6 and then J7.

**PXi image processor:** Insert a DRAM SIMM in connector J6 (or in J7 if J6 is already filled) (a), and tilt the module upright until it locks in place (b). Repeat Step 6 to install additional memory modules.

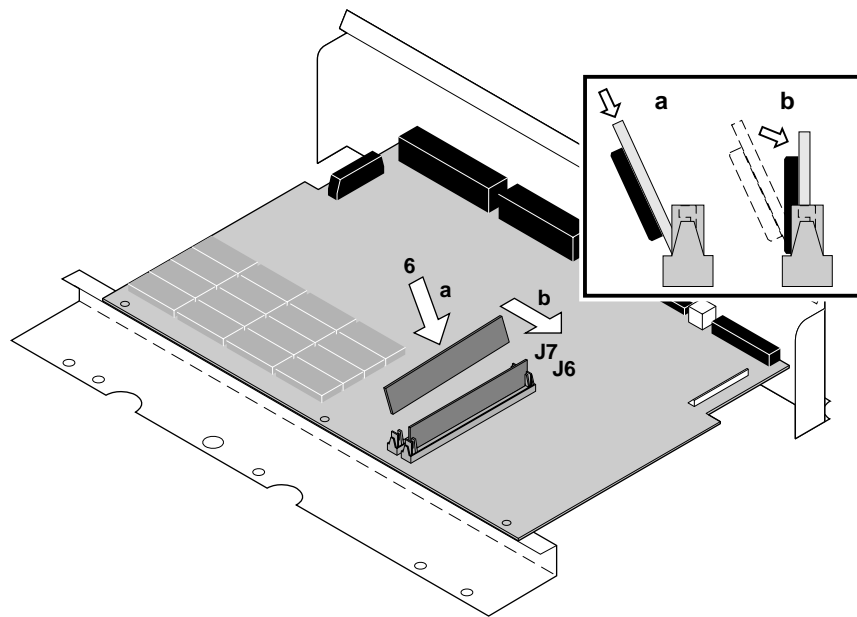

When properly inserted, a tab on each end of the connector slips into a hole on each end of the memory module. Also, a pawl on each end of the connector latches around each end of the memory module to lock it in place.

7. Reinstall the EMI shield and the top panel. Reconnect the front panel connector.
8. Reconnect the host interface cables. Turn on the printer and make a test print to ensure that the printer functions correctly.

## Phaser III PXi Phaser 300i

1. Power down the printer. Do not unplug the printer; this preserves a ground path to dissipate static charges. Disconnect the host interface cables.
2. Remove the two screws securing the image processor board in place. Grasp underneath the rear panel and slide the image processor board out of the printer card cage. *Do not pull on the connector bails.*

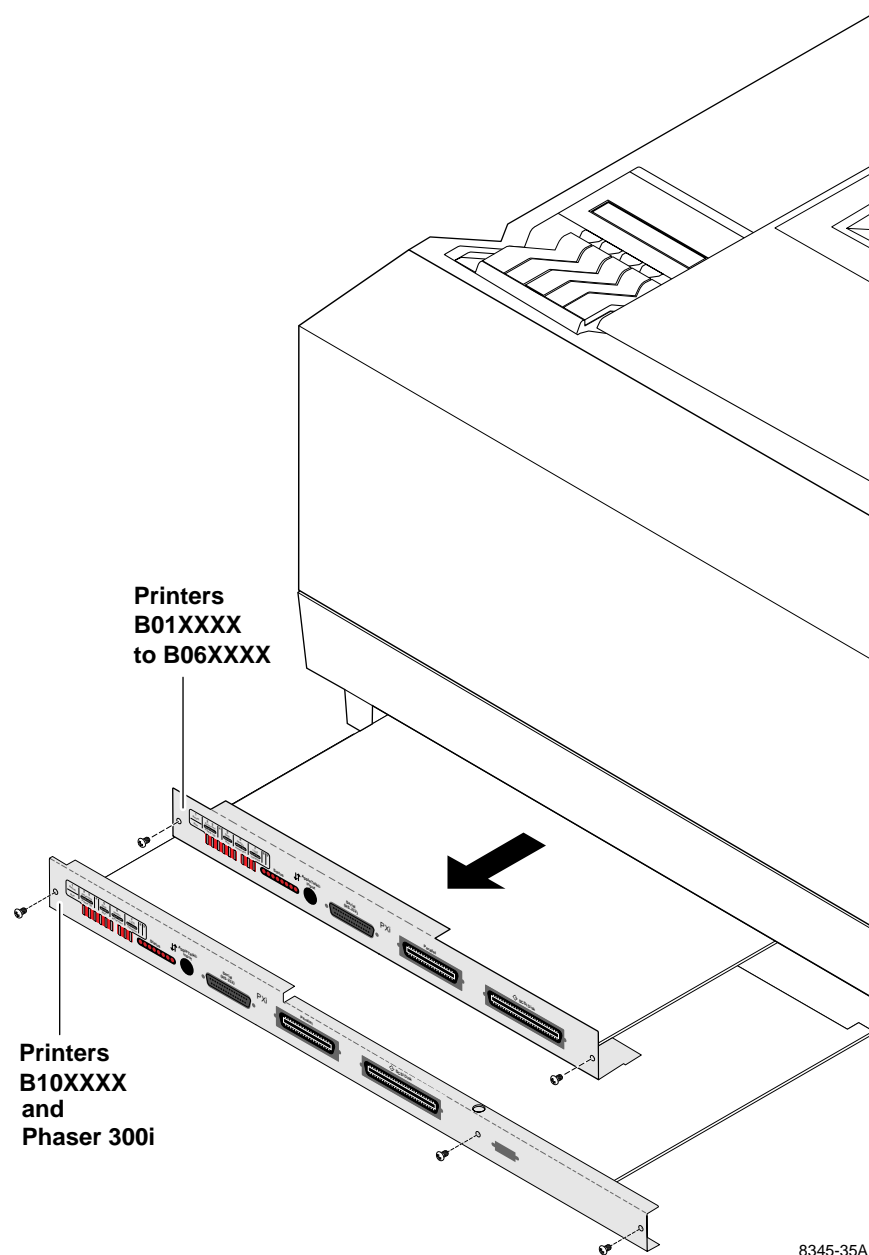

8345-35A

**Note** For Phaser III printers serial numbered B01xxxx to B06xxxx:  
Install memory modules in the order J7 and then J8. J6 should already  
be filled.

3. Insert a memory module in connector J7 (**a**), and tilt the module upright until it locks in place (**b**). Repeat to install additional memory module in J8.

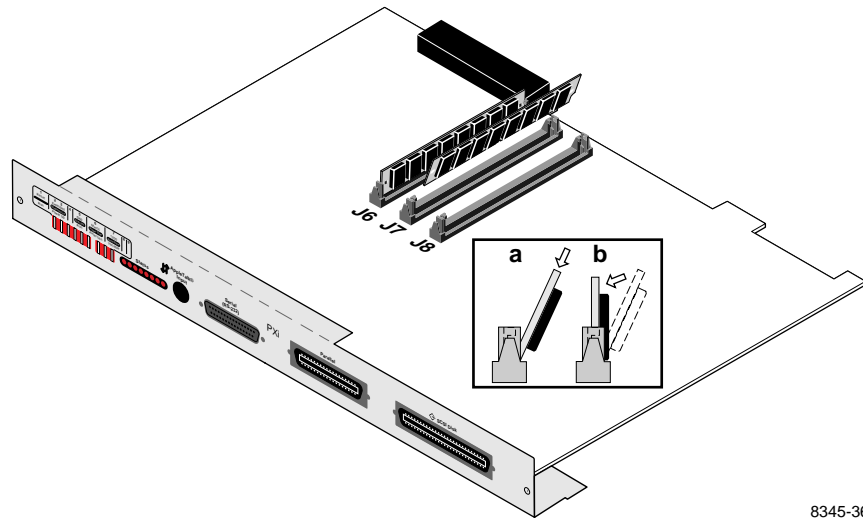

8345-36

**Note** For Phaser III printers serial numbered B10xxxx and higher and Phaser 300i printers: Install memory modules in the order J8 and then J7. J9 should already be filled.

Insert a memory module in connector J8, or in J7 if J8 is filled (a), and tilt the module down until it locks in place (b).

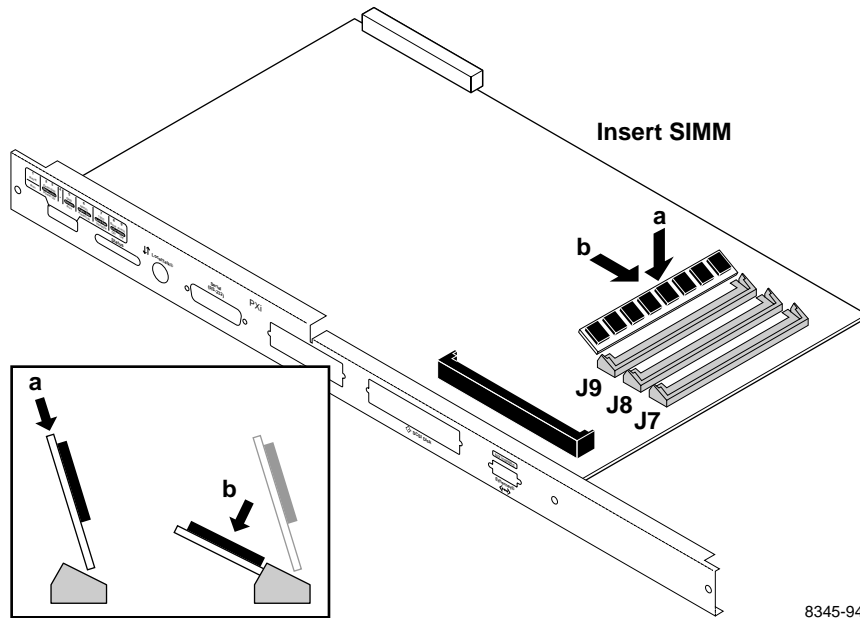

4. Repeat Step 3 to install additional memory modules.

When properly inserted, a tab on each end of the connector slips into a hole on each end of the RAM SIMM. Also, a pawl on each end of the connector latches around each end of the RAM SIMM to lock it in place.

5. Reinstall the board in place and secure with the two screws.
6. Reconnect the host interface cables. Turn on the printer and make a print to ensure the printer functions correctly.

## Phaser II SX/DX (slide-in style image processor board)

1. Turn the printer off. Do not unplug the printer; this preserves a ground path to dissipate static charges. Disconnect the host interface cables.
2. Loosen the rear panel thumbscrews.

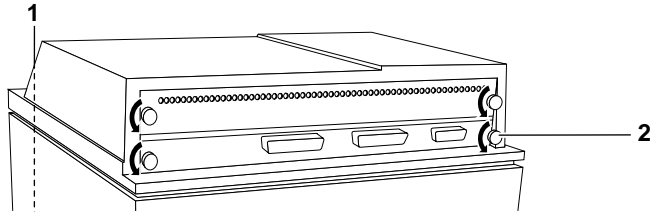

31113-9

3. If just the image processor board is installed, then slide the image processor board out of the printer. If the printer is equipped with a multiplexer, then slide both the image processor board and the attached 3-port multiplexer out of the printer.
4. Lay the image processor board (and the multiplexer, if attached) on a flat, static-free surface.
5. Locate the connectors labeled SIMM #1, #2, and #3 on the image processor board. (For the Phaser II DX printer, a memory module is already installed in connector SIMM #1.)

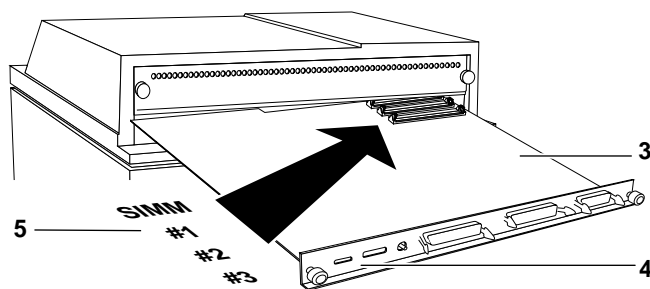

31113-10

**Note** Install memory modules in the order #1, then #2, and then #3.

6. Insert a memory module in connector SIMM #1 (or in SIMM #2 if SIMM #1 is already filled) **(a)**, and tilt the module upright until it locks in place **(b)**.
7. Repeat Step 6 to install an additional memory module.

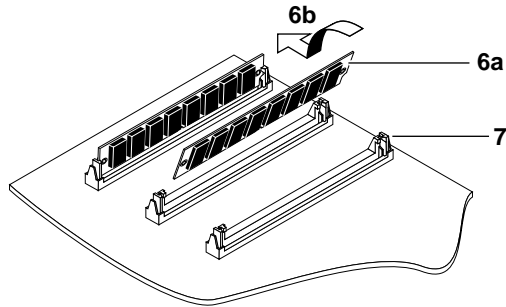

31113-11

8. Slide the 3-port multiplexer board, if the printer is furnished with one, into the top slot. Slide the image processor board into the bottom slot. Push and turn the thumbscrews to secure the board(s) in place.

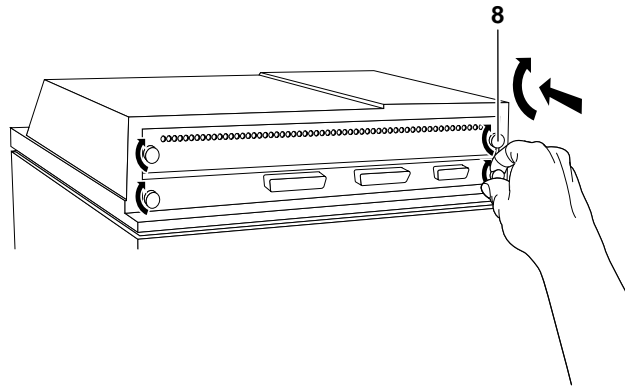

9. Reconnect the host interface cables. Turn the printer on and make a test print to ensure that the printer prints correctly.



## Phaser II SX/DX (bolt-down style image processor board)

1. Power down the printer. Do not unplug the printer; this preserves a ground path to dissipate static charges. Disconnect the host interface cables.
2. Remove the top panel. Three of the screws securing the top panel are at the rear of the printer. Open the top cover to access the three other screws located on the front underside of the top cover. (Be careful lifting the cabinet top; the front panel cables are still attached.)
3. Disconnect the front panel LED connector. For DX printers, disconnect the front panel LCD connector.

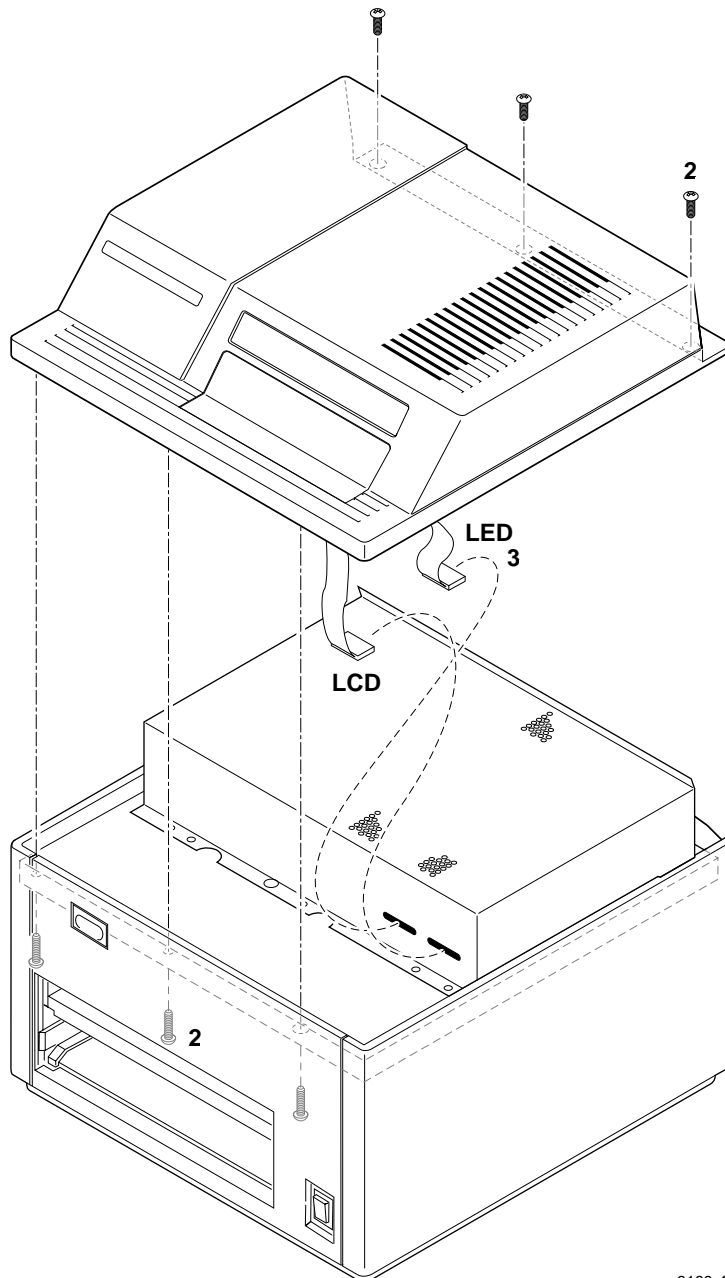

R100.12

4. Remove the two screws securing the front of the EMI shield. Tilt the shield up and remove it.

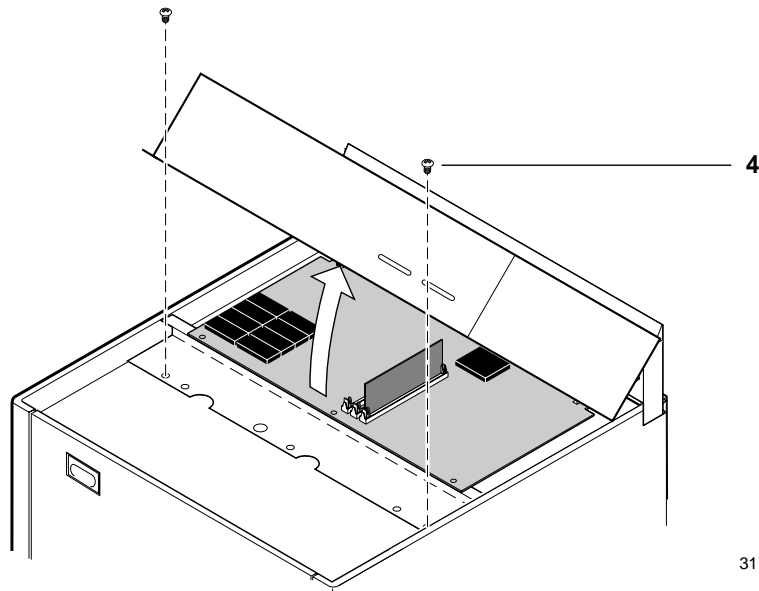

31113-13

5. Locate the connectors labeled SIMM #1, #2, and #3 on the image processor board. (For the Phaser II DX printer, a memory module is already installed in connector SIMM #1.)

**Note** *Install memory modules in the order #1, then #2, and then #3.*

6. Insert a memory module in connector SIMM #1 (or in SIMM #2 if SIMM #1 is already filled) **(a)**, and tilt the module upright until it locks in place **(b)**.

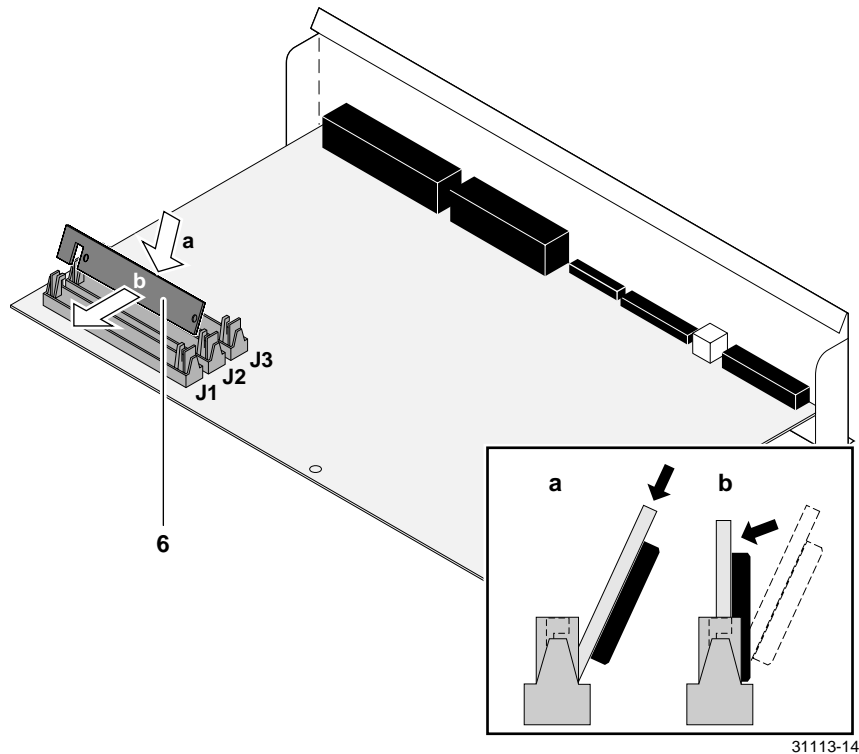

When properly inserted, a tab on each end of the connector slips into a hole on each end of the SIMM. Also, a pawl on each end of the connector latches around each end of the SIMM to lock it in place.

7. Repeat Step 6 to install an additional memory module.
8. Reinstall the EMI shield and the top panel. Reconnect the host interface cables. Turn on the printer and make a test print to ensure that the printer functions correctly.

## Phaser II SD/SDX

1. Power down the printer. Do not unplug the printer; this preserves a ground path to dissipate static charges.
2. Remove the cabinet top. (Be careful lifting the cabinet top, the front panel LED cable is still attached.)
3. Disconnect the front panel LED connector.

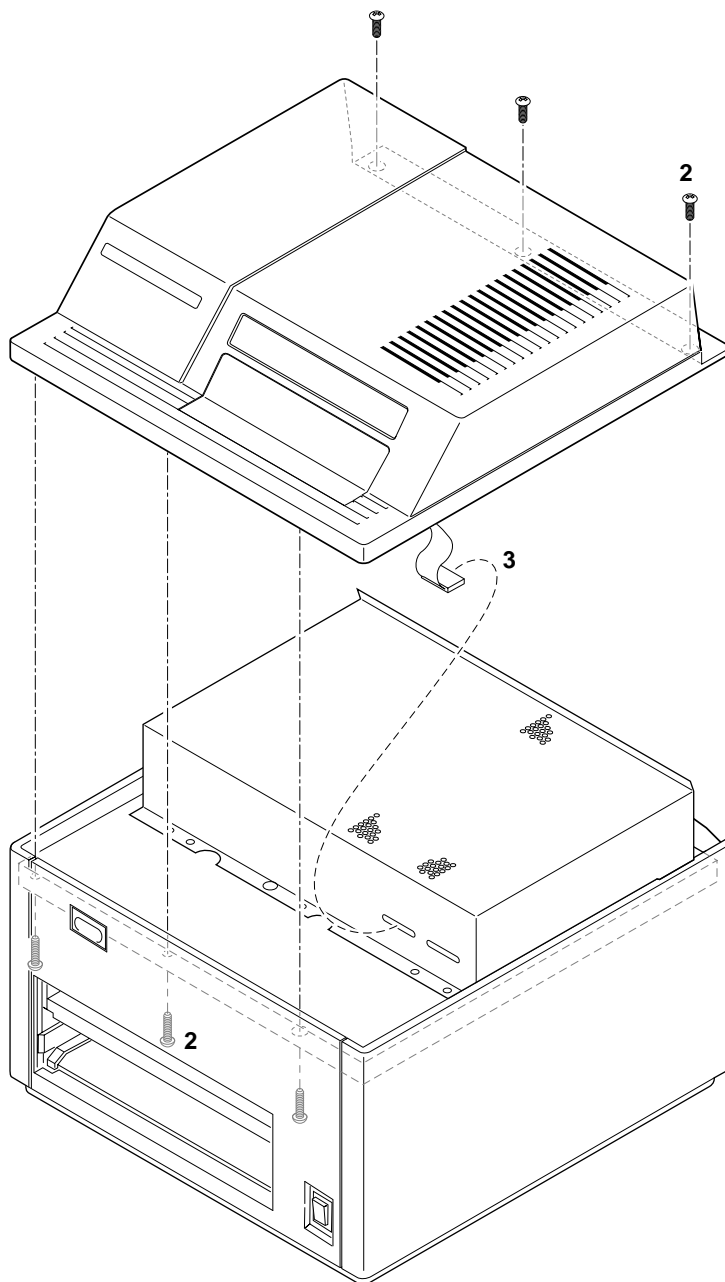

4. Remove the two screws securing the front of the EMI shield. Tilt the shield up and remove it.

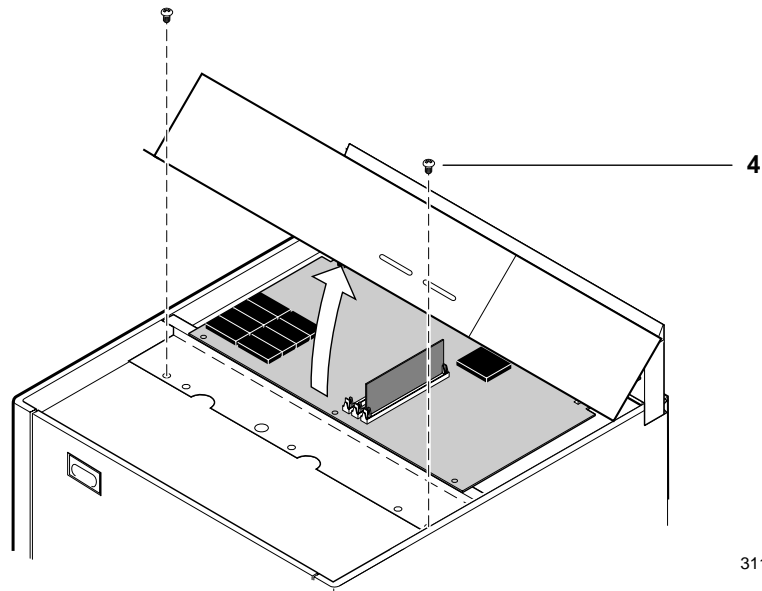

5. Locate the DRAM SIMM module connector J6.
6. Insert a keyed DRAM SIMM in connector J6 (or in J7 if J6 is already filled, or in J8 if J6 and J7 are already filled) **(a)**, and tilt the module upright until it locks in place **(b)**. Repeat Step 6 to install additional memory modules.

**Note** Install memory modules in the order J6, J7 and then J8.

When properly inserted, a tab on each end of the connector slips into a hole on each end of the memory module. Also, a pawl on each end of the connector latches around each end of the memory module to lock it in place.

**Note** The SD/SDX image processor accepts both 4-Mbyte and 16-Mbyte SIMMs. A single 4-Mbyte SIMM can be mixed with 16-Mbyte SIMMs only if the 4-Mbyte SIMM is the last SIMM installed. Install options:

J6	J7	J8
4 Mbyte	empty	empty
16 Mbyte	empty	empty
16 Mbyte	16 Mbyte	empty
16 Mbyte	16 Mbyte	16 Mbyte
16 Mbyte	4 Mbyte	empty
16 Mbyte	16 Mbyte	4 Mbyte

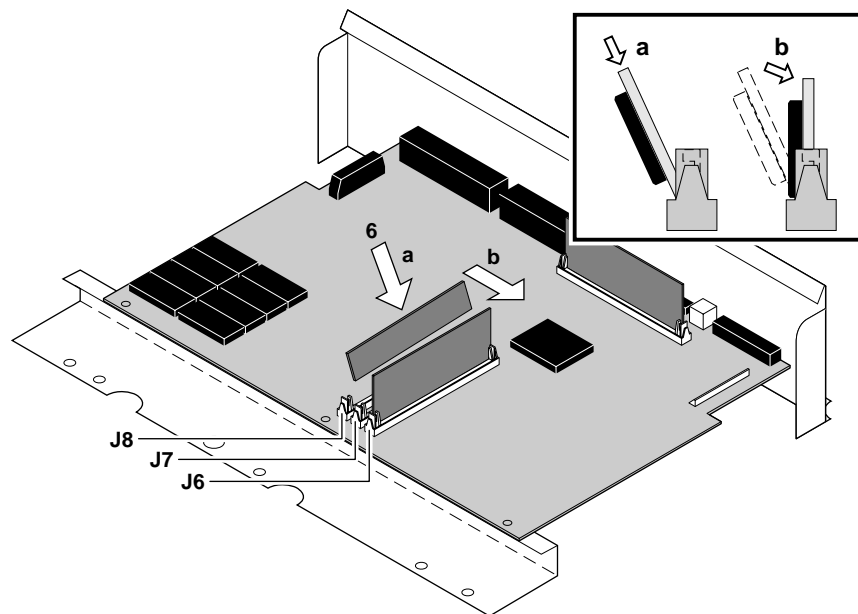

7. Reinstall the EMI shield. Reconnect the front panel connector. Reconnect the cabinet top.
8. Turn on the printer and make a print to ensure that the printer functions correctly.

## Phaser 200i and Phaser 200e

1. Power down the printer. Leave the power cord plugged in to provide a ground path for static. Remove the interface cables.
2. Remove the top-rear and rear cabinet panels.
3. Remove the screws securing the I/O board to the card cage.
4. Disconnect the I/O board ribbon cable(s) from the image processor board. The Phaser 200i's I/O board has two ribbon cables; the Phaser 200e's I/O board has one ribbon cable. Remove the I/O board.

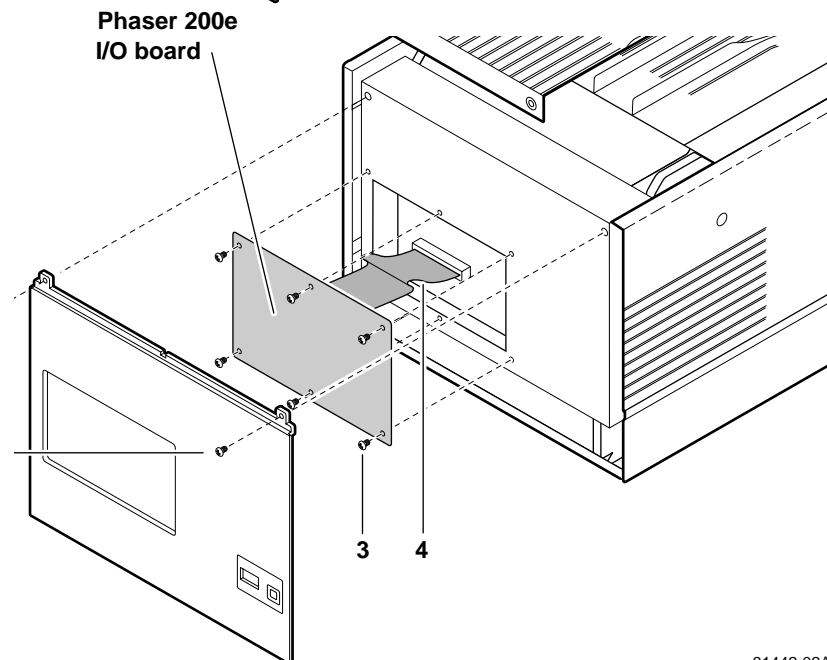
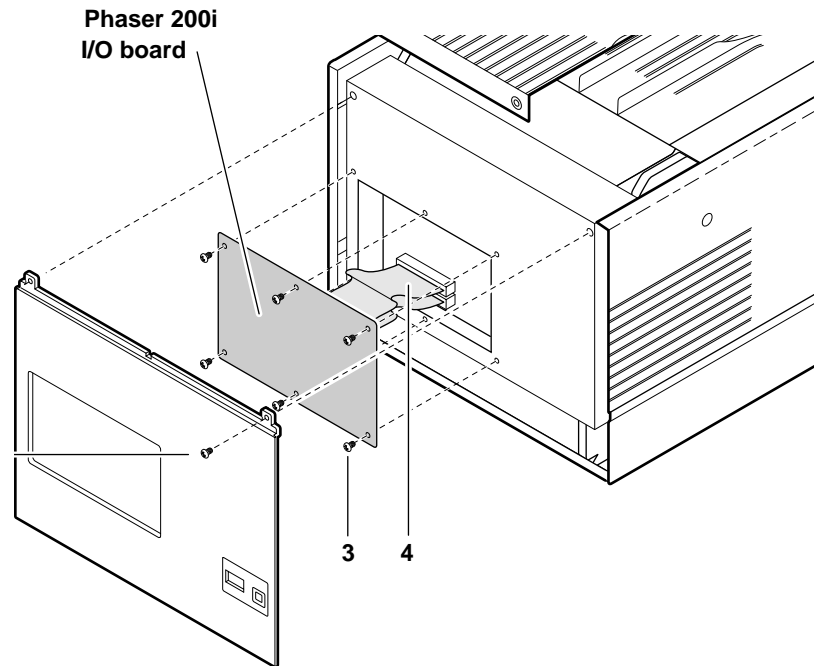

31442-02A

5. Remove the card cage top (3 screws).
6. Move over the hinged card cage top.
7. Lift out the image processor board.

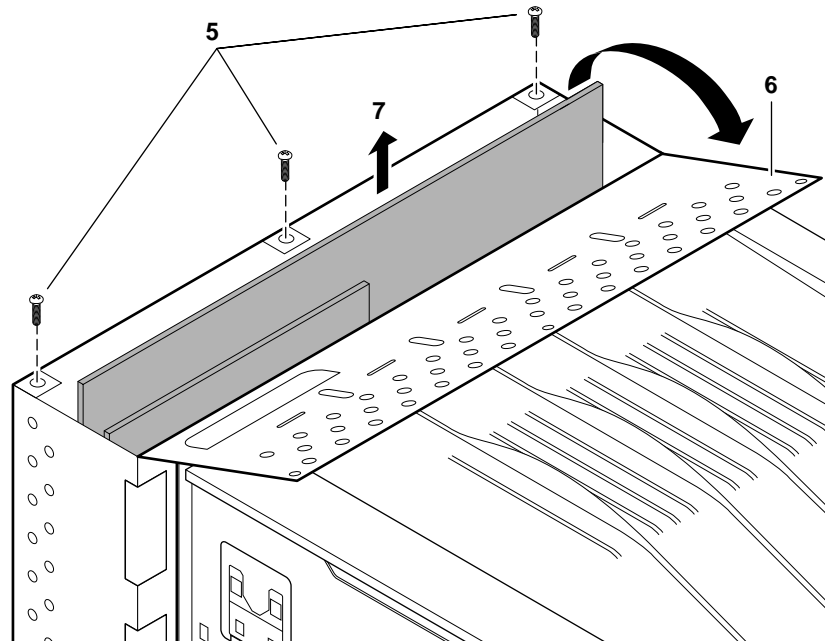



8. **Phaser 200e:** Insert a memory module in connector J6 (**a**), and tilt the module upright until it locks in place (**b**).

When properly inserted, a tab on each end of the connector slips into a hole on each end of the RAM SIMM. Also, a pawl on each end of the connector latches around each end of the RAM SIMM to lock it in place.

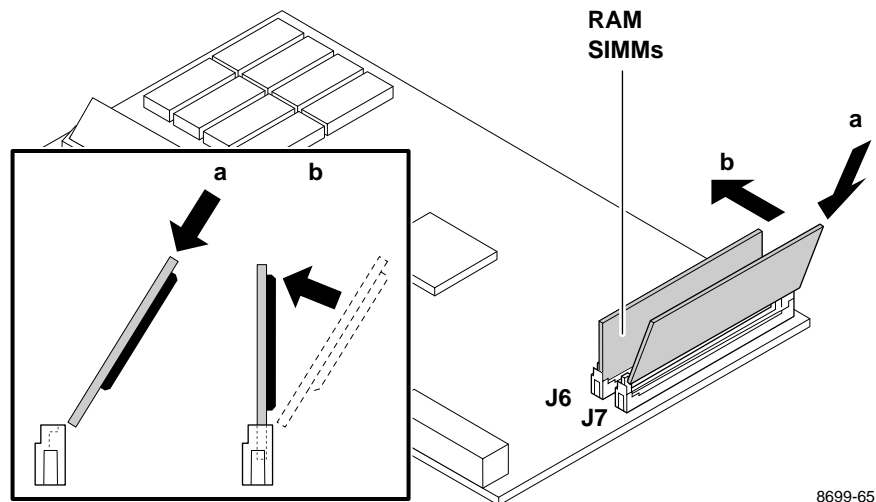

- Phaser 200i:** Insert a memory module in connector J6 (or in J7 if J6 is already filled) (**a**), and tilt the module upright until it locks in place (**b**).

When properly inserted, a tab on each end of the connector slips into a hole on each end of the RAM SIMM. Also, a pawl on each end of the connector latches around each end of the RAM SIMM to lock it in place.

9. **Phaser 200i only.** Repeat Step 8 to install an additional memory module in J7 if a second SIMM is available.
10. Reinstall the image processor board in the card cage.
11. Reinstall the I/O board.
12. Close and secure the card cage top. Reinstall the rear cabinet panels.
13. Reconnect the host interface cables. Turn on the printer and make a print to verify that the printer functions correctly.